

ASSEMBLY TOOLS	
DESCRIPTION	PART NO.
FOR INSTALLATION AND REMOVAL OF SHAFT GUIDE & DIAPHRAGM PLATE (TOOL NOT SHOWN)	1074989

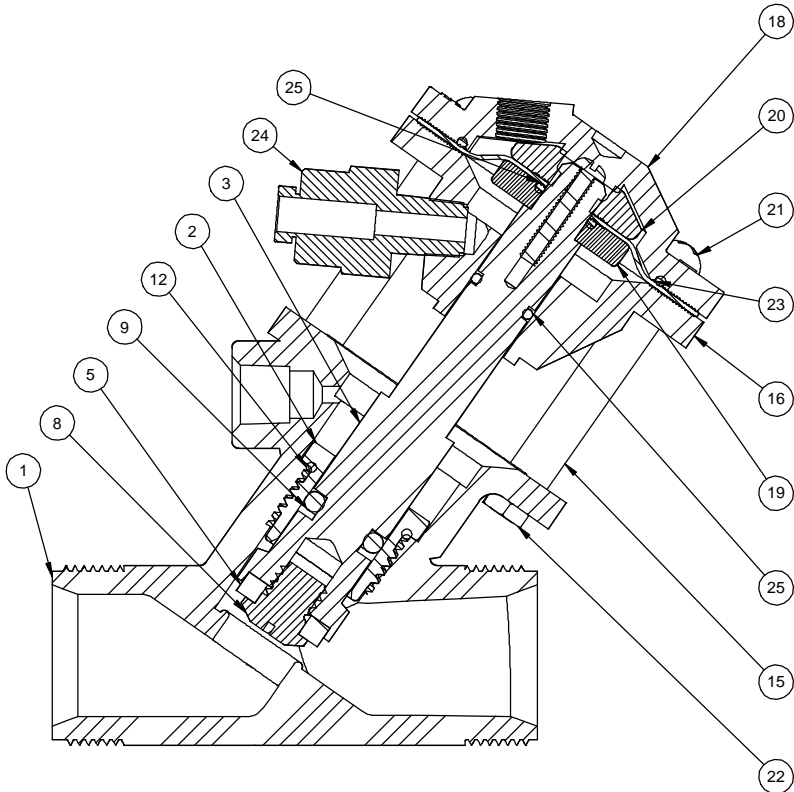

**1071402 (K550-X200-1400)
NORMALLY OPEN (STANDARD)**

REVISIONS					
ZONE	ECN	REV.	DESCRIPTION	DATE	APPD
	102124	J	REDRAWN IN SOLIDWORKS, FORM # NOW DWG #, WAS-1084013	06-25-13	TJM

ITEM NO.	DESCRIPTION	PART NUMBER	QTY.
1	BODY, K520	1074943	1
2	SCREW, DISC, PLATE, 520, NORYL	1077903	1
3	DISC,	E.P.D.M.	1074966
		BUTYL	1074967
		FKM	1074968
4	SHAFT, K5520	1075335	1
5	GUIDE, SHAFT, 520, NORYL	1074964	1
6	O-RING, -204	E.P.D.M.	1071740
		BUTYL	1071774
		FKM	1071812
7	O-RING, 2-012, NITRILE	1071668	2
8	DIAPHRAGM, 520 (NBR)	1074962	1
9	O-RING, (EPDM) -030	3015801	1
10	BOTTOM DIAPHRAGM PLATE,	1075339	1
11	PLATE, DIAPHRAGM, UPPER, 520	1074958	1
12	CAP, 520	1074948	1
13	BOTTOM CAP,	1075334	1
14	SCREW, 10-32X 5/8", RND HD, SS	1072379	6
15	STANDOFF,	1075338	3
16	HEX NUT, 10-32, SS	1071647	6
17	O-RING, -018	E.P.D.M.	1071720
		BUTYL	1071762
		FKM	1071790
18	CONNECTOR, 1/8 MNPT X 1/4T, PLS	1078767	1

REPAIR PARTS KITS			
DESCRIPTION	PART NO.		
DIAPHRAGM & SEALS KIT CONSISTS OF ITEM NO'S 3, 6, 7, 8, 9, 17	1075341 EPDM INCLUDES DIAPHRAGM 1074962	1075342 BUTYL INCLUDES DIAPHRAGM 1074962	1075343 FKM INCLUDES DIAPHRAGM 1074962
INTERNAL PARTS KIT (NORMALLY OPEN) CONSISTS OF ITEM NO'S 2, 4, 5, 10, 11, 18	1071432		

SEE SHEET 1078140 FOR UNION END CONNECTORS,
SEE SHEET 1078141 FOR GROOVED ADAPTORS

SEE REVERSE SIDE FOR CONFIGURATION OPTIONS

16605 West Victor Rd New Berlin, WI 53151 www.aq-matic.com	THIRD ANGLE PROJECTION				
	APPROVALS				DATE
DO NOT SCALE DRAWING. DIMS. ARE IN INCHES (mm) INTERPRET DIMS AND TOLERANCES PER ASME Y14.5M - 2009 UNLESS OTHERWISE SPECIFIED:	DRAWN	MWL	06-25-13	TITLE	CATALOG SHEET, 5520
	APPROVED			SIZE	C
TOLERANCES: ANGLES: ±.1° 1 PLACE .X: 2 PLACE .XX: 3 PLACE .XXX:	CHECKED			DWG NO.	1077692
				SCALE	1:1
				SHEET 1 OF 2	

REVISIONS					
ZONE	ECN	REV.	DESCRIPTION	DATE	APPD

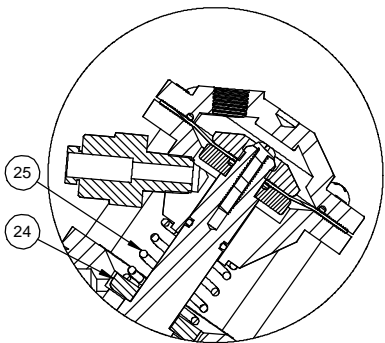

1071406 (K550-X203-14000)
FAILSAFE SPRING CLOSED 30 PSI

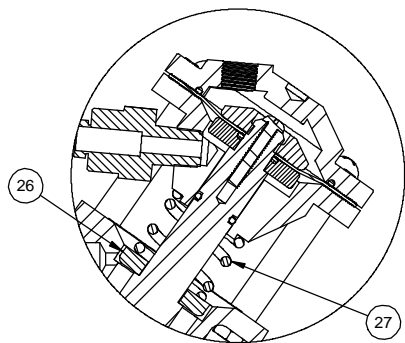

1071409 (K550-X204-14000)
FAILSAFE SPRING CLOSED 60 PSI

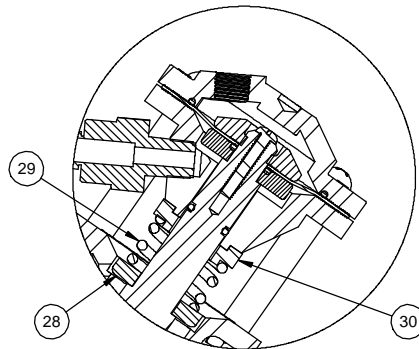

1071412 (K550-X205-14000)
FAILSAFE SPRING CLOSED 100 PSI

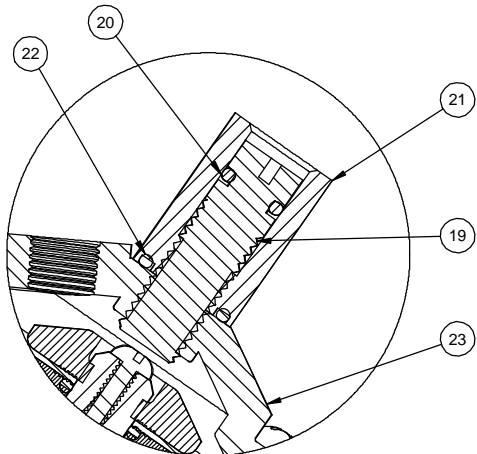

1071414 (K550-X214-14000)
LIMIT STOP

REPAIR PARTS KITS	
DESCRIPTION	PART NO.
INTERNAL PARTS KIT (LIMIT STOP) CONTAINS ITEM NO'S 19 THRU 22	1074973

CONVERSION KITS	
DESCRIPTION	PART NO.
CONVERSION PARTS KIT (LIMIT STOP) CONTAINS ITEM NO'S 19 THRU 23	1071056

LIMIT STOP MODEL			
ITEM NO.	DESCRIPTION	PART NUMBER	QTY.
19	LIMIT STOP SCREW, SERIES 520	1074988	1
20	O-RING,2-010,NITRILE	1071667	1
21	LIMIT STOP NUT,	1074987	1
22	O-RING,2-013,NITRILE	1071669	1
23	CAP, LIMIT STOP, 520	1074946	1

FAILSAFE SPRING CLOSED - 30 PSI			
ITEM NO.	DESCRIPTION	PART NUMBER	QTY.
24	SPRING,RETAINER,BLACK	1075344	1
25	SPRING, COMPRESSION	3007473	1

FAILSAFE SPRING CLOSED - 60 PSI			
ITEM NO.	DESCRIPTION	PART NUMBER	QTY.
26	SPRING,RETAINER,BLACK	1075344	1
27	SPRING,	1075053	1

FAILSAFE SPRING CLOSED - 100 PSI			
ITEM NO.	DESCRIPTION	PART NUMBER	QTY.
28	SPRING,RETAINER,BLACK	1075344	1
29	SPRING,	1075053	1
30	CENTERING COLLAR,	1075337	1

NOTE:

- LIMIT STOP OPTION ONLY OFFERED ON FAIR SAFE SPRING CLOSE MODELS.
- FAILSAFE OPTION NOT OFFERED IN CONVERSION KIT FORM DUE TO SPECIAL ASSEMBLY REQUIREMENTS.

SEE SHEET 1078140 FOR UNION END CONNECTORS,
SEE SHEET 1078141 FOR GROOVED ADAPTORS,

SEE REVERSE SIDE FOR
STANDARD NORMALLY OPEN CONFIGURATION

16605 West Victor Rd New Berlin, WI 53151 262-326-0100 www.aq-matic.com	THIRD ANGLE PROJECTION	
	APPROVALS DATE	
<small>DO NOT SCALE DRAWING. DIMS. ARE IN INCHES (mm) INTERPRET DIMS AND TOLERANCES PER ASME Y14.5M -2009 UNLESS OTHERWISE SPECIFIED:</small>	DRAWN MWL 06-25-13	SIZE C
<small>TOLERANCES: ANGLES: ±1° 1 PLACE .X; 2 PLACE .XX; 3 PLACE .XXX;</small>	APPROVED CHECKED	DWG NO. 1077692
	SCALE 1:1	REV J
		SHEET 2 OF 2